

C-1018

Banco MAVERIK

Revision: 01 - 27/10/2016

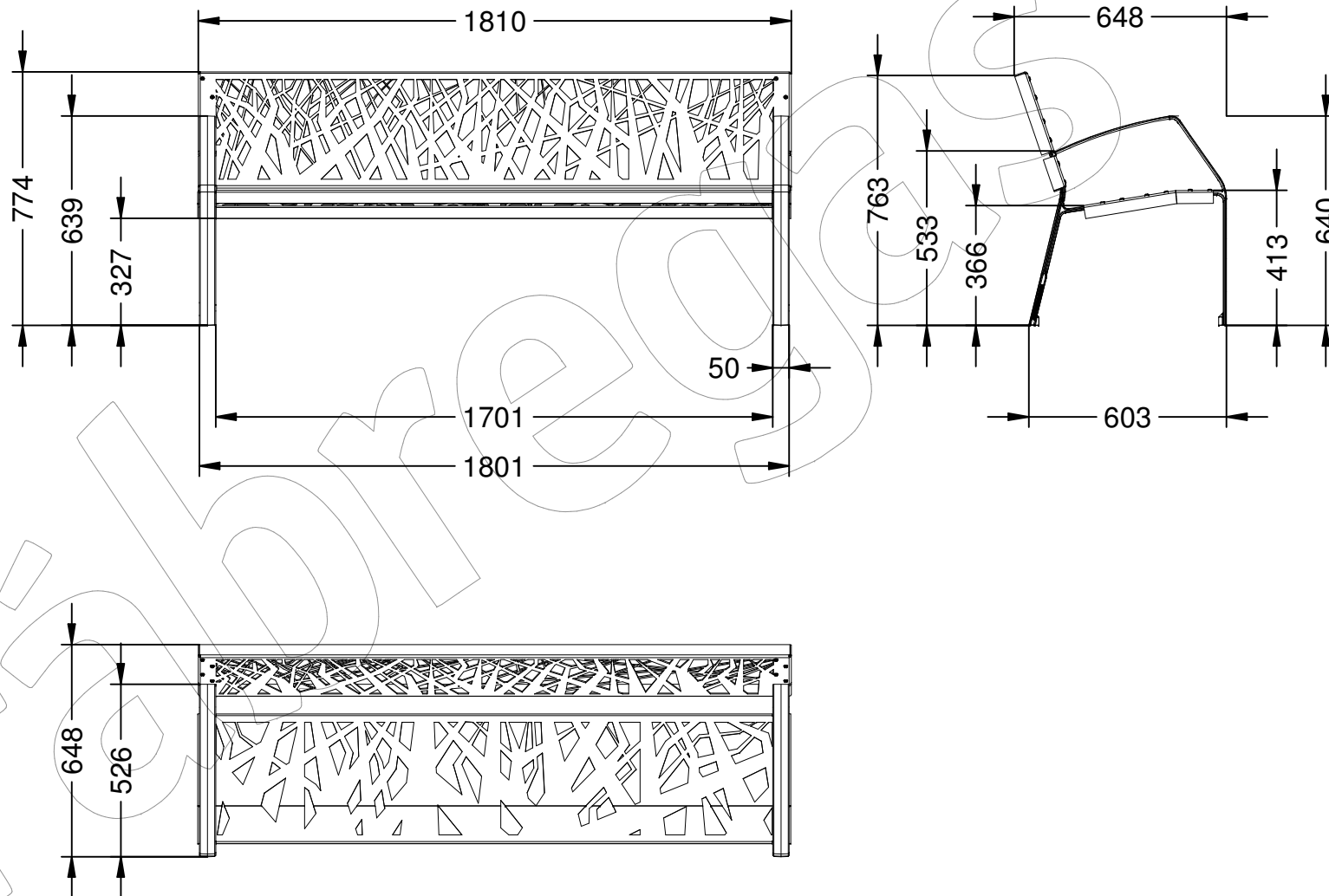

C-1018

Banco MAVERIK

Revision: 01 - 27/10/2016



-ES- 

Descripción:

Asiento y respaldo: Chapa de acero.

Pata: Fundición dúctil EN-GJS-500-7.

Acabado: Imprimación y pintado al horno.

Se suministra desmontado.

-EN- 

Description:

Seat and back: Sheet steel.

Paw: Ductile iron EN-GJS-500-7.

Paint finish: Primer and painted in the oven.

Supplied disassembled.

-PT- 

Descrição:

Assento e encosto: Em chapa de aço.

Perna: Ferro fundido dúctil EN-GJS-500-7.

Acabamento: Primer e pintado no forno.

É fornecido desmontado.

-CA- 

Descripció:

Seient i respallter: Xapa d'acer.

Pota: Fosa dúctil EN-GJS-500-7.

Acabat: Imprimació i pintat al forn.

Es subministra desmuntat.

-FR- 

Description:

Assise et dossier: Tôle d'acier.

Jambe: Fonte ductile EN-GJS-500-7.

Finition: Apprêt et peints dans le four.

Il livrés démontés.

C-1018

Banco MAVERIK

Revision: 01 - 27/10/2016

Instrucciones de montaje:

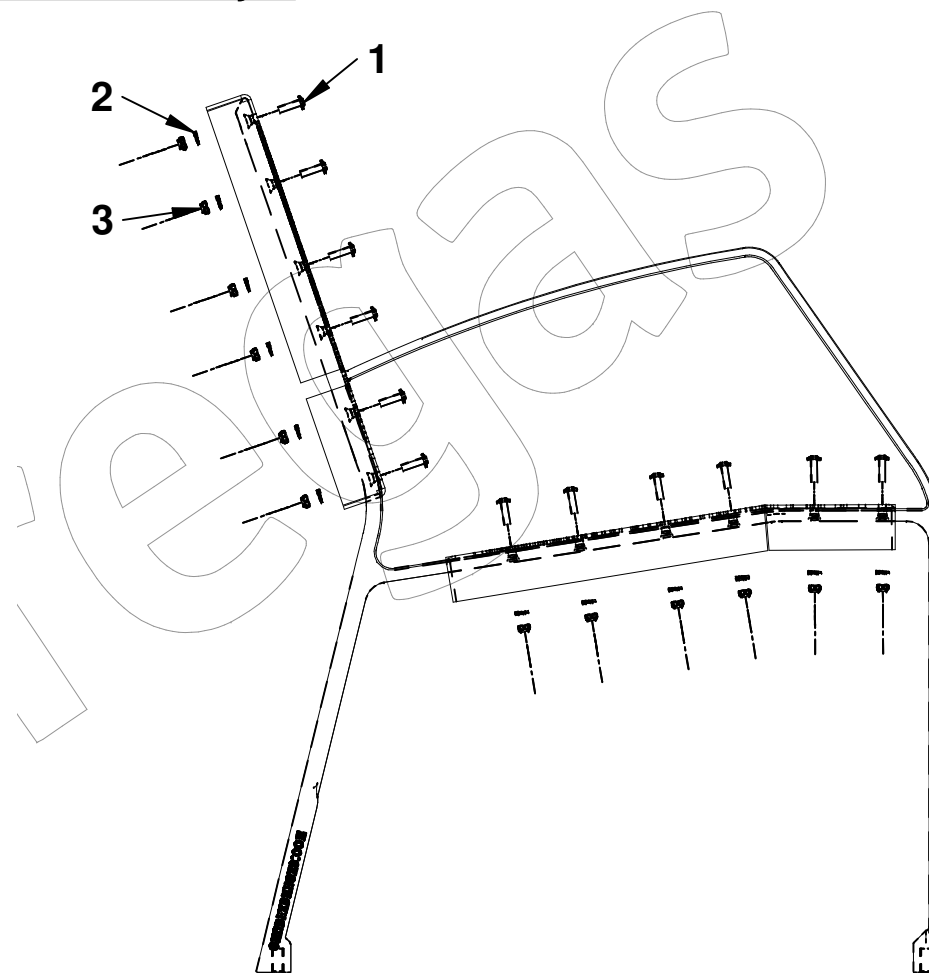

1: Tornillo DIN 7380 con arandela M6 INOX.

2: Arandela Grower DIN 127B M6 INOX A4.

3: Tuerca autoblocante DIN 985 M6 A2.